

8.1.1 TECHNICAL DATA

MAX OPERATING PRESSURE (PS): 360 bar

PRESSURE SETTING (P): 10 ÷ 360 (upon request)

ORIFICE: 9.5 mm

LIFT: 2 mm

WORKING TEMPERATURE: -40 ÷ +150 °C

REPETIBILITY: ± 3% of P

CALIBRATION ERROR: < 3%

OVERPRESSURE BY FULL FLOW: 10% of P

BLOW DOWN: 10% of P

GAS DISCHARGE COEFFICIENT (K): 0.95

LIQUID DISCHARGE COEFFICIENT (K): 0.6

BODY MATERIAL: stainless steel AISI 316L

SEALING MATERIAL: Delrin (POM)

CONNECTIONS: 3/4" BSP ISO228

FLOW RATE: see Table 5.1d

WEIGHT: see Table 5.1d

8.1.2 DESCRIPTION

The safety valves VS224 are designed and manufactured by Epe Italiana. They have soft seal and total lift. They have a high flow coefficient ($K = 0.95$) and are suitable for gas and liquids.

VS224 valves are safety devices as specified in Article 1, Section 2.1.3 of Directive 97/23/EC and are subject to Article 3, Section 1.4 of the same Directive.

These valves are direct acting safety valves, used for protection against overpressure with respect to the operating conditions of the accumulators. They can be installed directly on the accumulator, through the appropriate use of adapters (see Cap.8.3) or on the safety block on the gas side (BC32G) or on joint on the gas side connection of the accumulator stations.

The valve opening is determined by the force exerted by the fluid under pressure on the poppet in contrast with the spring acting on the cut-off itself.

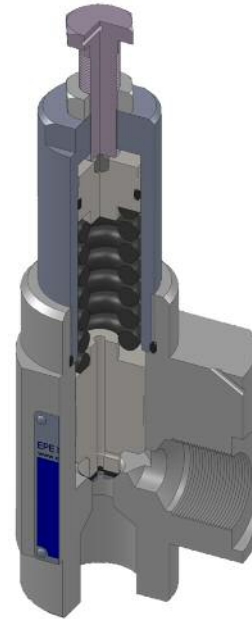

8.1a

8.1.3 HYDRAULIC SYMBOL

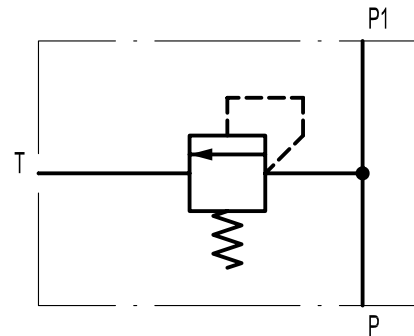

8.1b

8.1.4 CONSTRUCTION

Body: of stainless steel AISI316L, obtained by mechanical processing, in which are obtained the connections and the seal seat.

Poppet: obtained by mechanical processing from bar and provided with a seal, it ensures the necessary seal degree on the valve seat. The seal is made of DELRIN (POM), a material that, over the estimated useful life for the valve, maintains good strength and does not cause phenomena of poppet sticking on the seat. The poppet is well led and pushed by the spring.

Spring: it counteracts the pressure and the dynamic actions of the fluid and always ensures the closing of the valve after the discharge.

The coils of the spring, even when the poppet has reached its maximum lift, are never at pack.

The poppet has a mechanical lock and when it has reached it, the arrow of the spring does not exceed 85% of the maximum deviation.

Calibration system: threaded hexagon head screw which screws into the top of the valve by compressing the spring below. After the calibration, the position of the adjusting screw is kept unaltered by locking the counter nut and sealing the adjusting screw to the body.

8.1.5 CALIBRATION

All valves are calibrated on the working bench with atmospheric counter pressure. The repeatability error of calibration is less than 3% of P. The leak test is performed according to API Standard 527: with air under water and up to a pressure equal to 97% of the calibration pressure verifying that, there's no beackages.

8.1.6 ORDER CODE

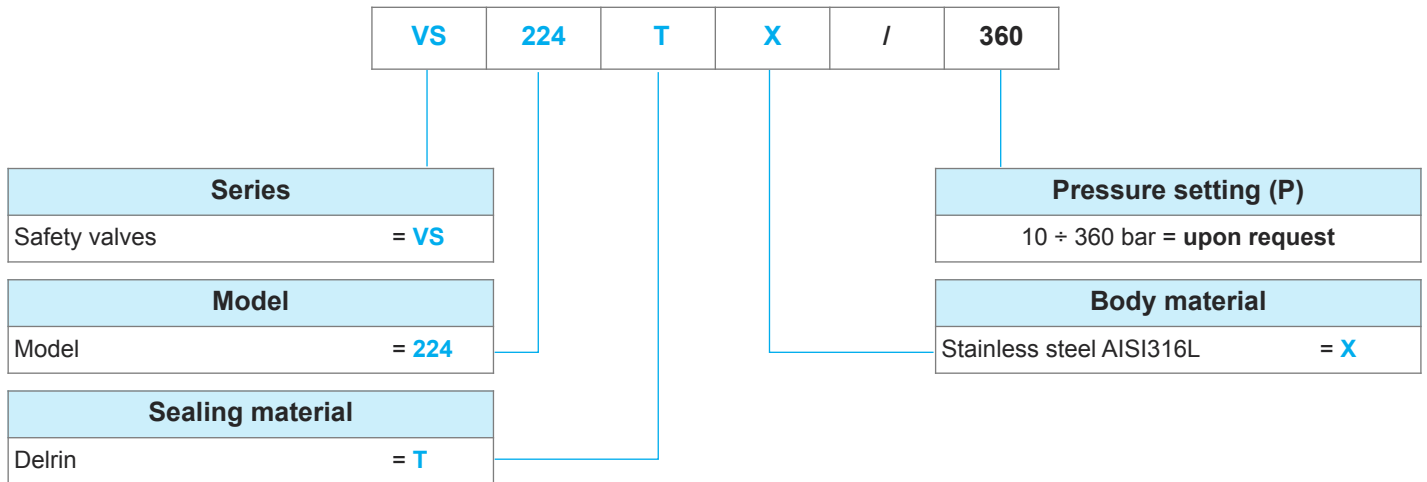

Special variants upon request

8.1.7 DIMENSIONS

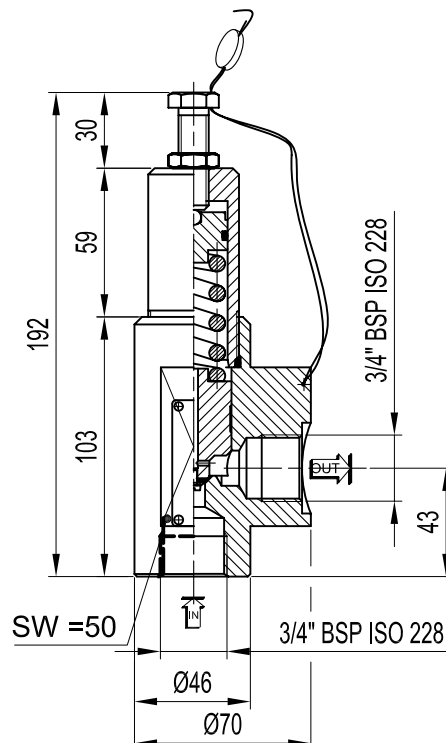

8.1.8 EUROPEAN MARKET

Directive 97/23/EC provides that pressure equipment, in which it's reasonably expected to be exceeded the allowable limits, should be provided with adequate protective equipment; for example, safety accessories such as safety valves type VS or burst disk type DR (see Chap. 8.2). These devices shall prevent that pressure permanently exceeds the maximum allowable pressure PS of the equipment protected by them.

However, it is permissible a pressure peak of short duration limited to 10% of the maximum allowable pressure.

For the choice and sizing of the adequate safety device, the user should refer to specific standards.

In accordance with the regulations 97/23/EC, the safety valves are classified in Category IV.

8.1.9 ACCESSORIES

Two-way shut-off valves, see Chap. 8.4

Three-way shut-off valves, see Chap. 8.5

Gas side dumpers, see Chap. 8.3

8.1.10 COMMISSIONING AND MAINTENANCE

Installing the valves

Regarding the installation of the safety valves, you should be kept in mind the following key points:

- the safety valves must be installed in the area that need to be protected from overpressure in the vertical position with the inlet connection facing down;
- the vessels, connected each other by appropriate piping with a diameter adapted by the Manufacturer and User and on which there weren't interposed interceptions, can be considered for the installation of the safety valves, as a single vessel;
- the connection between the valve and the equipment to be protected should be as short as possible and must not have a cross section smaller than the one of the valve inlet. In any case, the standard EN 13136:2001/A1: 2005 states that the pressure drop between the protected vessel and the safety valve, at flow rate of full discharge, should not exceed 3% of the pressure value P, including any accessory inserted on the line;
- the choice of the safety valve displacement should consider that the operation of the valve results in the discharge of the gas under pressure, if not sent directly to atmosphere.

Where there is a risk of causing direct damage to individuals who are nearby, you will have to provide a pipe for conveying the discharge, sized so as not to affect the operation of the valve.

Standard EN 13136:2001/A1: 2005 requires that this pipeline should not generate, at full capacity, a pressure higher than 10% of the value of the calibration pressure for conventional unbalanced valves.

Disassembly

Before removing the valve, make sure that the plant on which it is mounted is not under pressure and that there is no pressure within the valve.

Ordinary maintenance

Checking the seals of the shutter and the seat on the system at each opening of the valve or every 6 months of operation. Periodic retest

according to the related standards of the country of installation. In Italy, see the Ministerial Decree 329 dd. 12/01/2004: for fluids of the group 1: every 2 years you must carry out a functional test and every 10 years you must check the integrity; for fluids of the group 2, every 3 years, you must check the operation and every 10 years you must check the integrity.

8.1.11 SIZING

Calculation according to ISO 4126-6

$$\text{Equation } Q = C \cdot K_b \cdot \alpha \cdot A \cdot P \cdot \text{radp} (M/T \cdot Z)$$

Definitions

A = mm ²	Minimum cross sectional flow area
Q = Kg/h	Mass flow rate
P = bar abs	Relieving pressure (=barg + 1.013)
K =	Isentropic exponent
C =	Function of isentropic exponent (=2.401 for k=1)
A =	Discharge coefficient (0.95)
T = °K	Relieving temperature
Z =	Compressibility factor
M = Kg/Kmol	Molecular factor
K _b =	Capacity correction factor for subcritical flow
P _b = bar abs	Back pressure

Examples

Gas: Nitrogen N₂

PRESS. SETTING 330 BAR	
DN	9.5 mm
A	70
P _b	1.013 bar abs
P _s	330 bar g
P	331.013 bar abs
T _s	80°C
T	353°K
M	29
Z	1
C	2,703
A	0,95
K _b	1

Mass flow rate calculation **Q = 17,000 Kg/h**

PRESS. SETTING 360 BAR	
DN	9.5 mm
A	70
Pb	1.013 bar abs
Ps	330 bar g
P	331.013 bar abs
Ts	80°C
T	353°K
M	29
Z	1
C	2,703
A	0,95
Kb	1

Mass flow rate calculation $Q = 18,600 \text{ Kg/h}$

8.1.12 EXAMPLES OF SAFETY VALVE ASSEMBLY

Direct mounting on a bladder accumulator



Direct mounting on a piston accumulator with nipple of $\frac{3}{4}$ "BSP



Mounting with shut-off 2-way valves (Chap. 8.4) to avoid discharging all the nitrogen in case of retest on the working bench or maintenance to the valve.



8.1f

Mounting with 3-ways shut-off valves (Chap. 8.5) to continue working safely with the second valve when it is necessary to remove the first for re-testing on the working bench or maintenance.



8.1d

8.1g

8.1e

Reproduction is forbidden.

In the spirit of continuous improvement, our products may be changed.